

## TO STUDY THE DEPENDENCE OF THE INTENSITY OF "ABSOLUTE BLACK MATTER " RADIATION ON TEMPERATURE AND DISTANCE

Boydedayev Sobirjon Rahimjonovich  
Namangan Engineering and Construction Institute

Umaraliyev Maksud Mahmudovich  
Namangan Engineering and Construction Institute

Turgunov Adham Rakhmatillayevich  
Namangan Engineering and Construction Institute

### ANNOTATION

Using the 1. Mall thermocouple, the relative intensity of radiation in an electric furnace with "black body" details in the temperature range of 300-750 K was measured.

2. To check the Stefan-Bolsman law, a graph of the dependence of radiation intensity on absolute temperature and distance was drawn.

**Keywords:** Heat capacity, thermal conductivity, molecule, individual plate, body temperature

### INTRODUCTION

All bodies radiate heat. The intensity of this heat electromagnetic radiation increases with increasing temperature and depends on the surface of the object. At a given wavelength, the better it absorbs light, the more heat it emits. [1] An object that absorbs heat of all wavelengths is called an absolutely black body. Kirchhoff was the first to propose the use of a closed space as a virtual absolute black body. An absolute black body has the highest absorption coefficient, and thus has the maximum possible radiation at a given temperature and wavelength. [2] It should be noted that thermal radiation has a contact spectrum in the cavity. [3] In order to check its spectral composition, it is necessary to enter the spectral quantities as well as the interval values  $u$  and  $I$ , which take into account all the frequencies in the radiation. For an infinitely small frequency range  $dv$ , we can say that the spectral volumetric density  $du_v$  is proportional to the range  $dv$ :

$$du_v = \rho_v dv. \quad (1)$$

$\rho_v \rightarrow$  coefficient is the spectral (volumetric) density of radiation.

For a continuous spectrum with frequencies from 0 to  $\infty$

$$u = \int_0^{\infty} du_v = \int_0^{\infty} \rho_v dv \quad (2)$$

Along with  $\rho_v \rightarrow$  it is possible to enter the spectral surface brightness of the radiation by describing it as in the introduction of integral quantities. In this case, there is a relationship between  $\rho_v$  and  $I_v$  as between  $u$  and  $I$ :

$$\rho_v = \frac{4\pi}{c} I_v. \quad (3)$$

$$\text{Vin formula. } \rho_v dv = v^3 F\left(\frac{v}{T}\right) dv. \quad (4)$$

Here  $F\left(\frac{v}{T}\right) \rightarrow$  is a function that can be explained only on the basis of thermodynamic equilibrium, that is, without any hypotheses about the molecular mechanism of radiation and absorption. [4] This allows us to calculate a curve corresponding to any other temperature based on the energy distribution curve in a given spectrum for a given temperature. [5] The formula (4) for the frequency  $\nu_1$ , which satisfies the condition  $\nu_1 = \frac{T_1 \nu}{T}$  when calculating  $\frac{\nu_1}{T_1} = \frac{\nu}{T}$  the curve for the temperature  $T_1$ , the curve for the temperature  $T$ , gives the following:

$$\rho(v_1, T_1) = v_1^3 F\left(\frac{v_1}{T_1}\right) = v_1^3 F\left(\frac{v}{T}\right) = \frac{T_1^3}{T^3} v^3 F\left(\frac{v}{T}\right) = \frac{T_1^3}{T^3} \rho(v, T). \quad (5)$$

The integral density of radiation  $u$  from (4) is as follows:

$$u = \int_0^\infty \rho_v dv = \int_0^\infty v^3 F\left(\frac{v}{T}\right) dv. \quad (6)$$

Enter a new variable  $v/T = \xi$  and write (6) as follows:

$$u = T^4 \int_0^\infty \xi^3 F(\xi) d\xi. \quad (7)$$

If we denote the magnitude of the integral by  $\alpha$ , then

$$u = \alpha T^4. \quad (8)$$

Stefan-Bolsman's law confirms that the total radiation emitted by an absolutely black body is proportional to the fourth degree of absolute temperature  $T$ . [6] ( $\alpha=5,67 \cdot 10^{-8} \text{ Wt}/(\text{m}^2 \cdot \text{K}^4)$  Stefan-Bolsman constant) [7] At this time, an absolutely black body also absorbs light from the environment. Thus, we do not measure the total luminosity  $u$ , but the luminosity of a source of radiation  $u'$  obtained from the radiation of an absolutely black body. The irradiance of radiation absorbed from the environment is as follows:

$$u_0 = \alpha T_0^4 \quad (9)$$

Therefore, it is possible to write:

$$u = \alpha(T^4 - T_0^4) \quad (10)$$

In this experiment, an electric furnace is used as an "absolute black body". The absolute black body details consist of a polished copper cylinder and a screen. A copper cylinder with one end insulated is inserted into an electric furnace and heated to the required temperature. If necessary, a water-cooled screen is installed in front of the electric oven so that only the heat radiation of the grinding cylinder can be measured, not the radiation of the outer walls of the boiling furnace. The temperature sensor NiCr-Ni was used to measure the temperature in the copper cylinder. Thermal radiation was measured using a Moll thermocouple connected to a microvolt meter. The thermocouple consists of a series of connected thermocouples. The measured points completely absorb the incident light, and the comparison points are at ambient temperature. Thus we obtained the output voltage of thermoelectric batteries  $u'$  as a measure of the relative radiance of the radiation source.

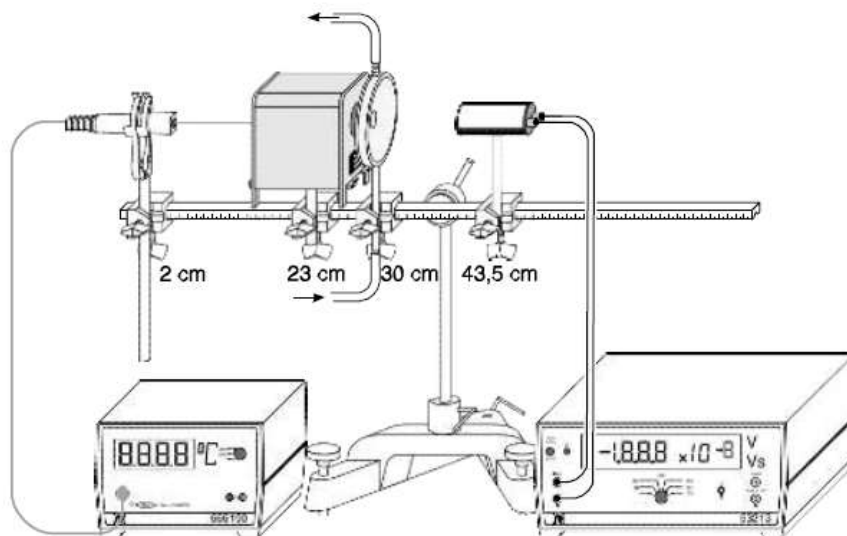

Picture. 1: An experimental device for confirming Stefan-Bolsman's law of thermal radiation.

**MEASUREMENT SAMPLES AND EVALUATION**

Table 1. Measured values for heating and cooling at a distance of 10 cm

t,°C	T,K	$(T^4 - 4)$	$U_h, V$	$U_c, V$
28	301	0	0	0
50	323	0.26	0	0
75	348	0.64	0.022	0.018
100	373	1.11	0.068	0.070
125	398	1.68	0.110	0.098
150	423	2.38	0.208	0.197
175	448	3.20	0.425	0.419
200	473	4.18	0.634	0.630
225	498	5.32	0.950	0.945
250	523	6.66	1.082	1.077
275	548	8.19	1.425	1.410
300	573	9.9	1.988	1.979
325	598	12.00	2.550	2.501
350	623	14.24	2.920	2.918
375	648	16.81	3.561	3.542
400	673	19.69	4.055	4.032
425	698	22.91	4.436	4.410
450	723	26.50	4.547	4.535

Table 2. Measured values for heating and cooling at a distance of 15 cm

t,°C	T,K	$(T^4 - 4)$	$U_h, V$	$U_c, V$
28	301	0	0	0
50	323	0.26	0	0
75	348	0.64	0	0
100	373	1.11	0.059	0.060
125	398	1.68	0.091	0.091
150	423	2.38	0.167	0.165
175	448	3.20	0.375	0.372
200	473	4.18	0.595	0.591
225	498	5.32	0.899	0.887
250	523	6.66	0.906	0.901
275	548	8.19	1.225	1.220
300	573	9.9	1.793	1.789
325	598	12.00	2.364	2.357
350	623	14.24	2.752	2.747
375	648	16.81	3.397	3.384
400	673	19.69	3.945	3.941
425	698	22.91	4.287	4.282
450	723	26.50	4.440	4.437

Table 3. Measured values for heating and cooling at a distance of 20 cm

t,°C	T,K	(T <sup>4</sup> - T <sub>0</sub> <sup>4</sup> )	U <sub>h</sub> ,V	U <sub>c</sub> ,V
28	301	0	0	0
50	323	0.26	0	0
75	348	0.64	0	0
100	373	1.11	0.045	0.045
125	398	1.68	0.075	0.077
150	423	2.38	0.112	0.110
175	448	3.20	0.294	0.288
200	473	4.18	0.425	0.422
225	498	5.32	0.742	0.739
250	523	6.66	0.915	0.913
275	548	8.19	1.023	1.019
300	573	9.9	1.454	1.448
325	598	12.00	1.952	1.947
350	623	14.24	2.295	2.284
375	648	16.81	2.779	2.776
400	673	19.69	3.225	3.217
425	698	22.91	3.854	3.842
450	723	26.50	4.187	4.184

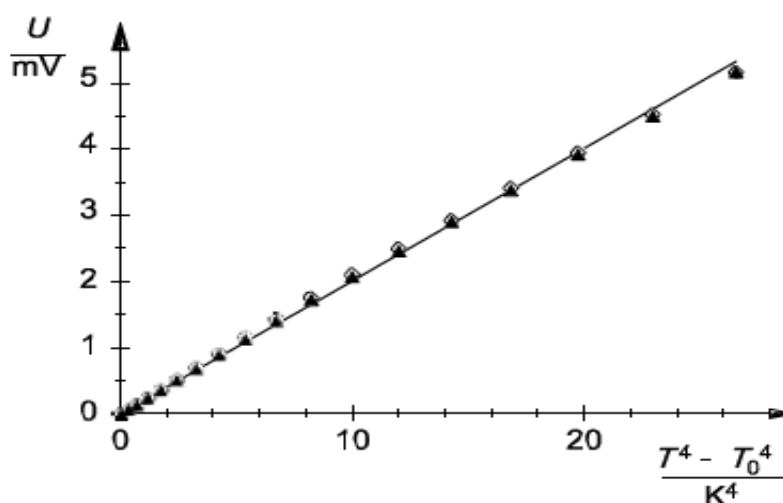

Figure 2: Graph of the output voltage U as a function of T<sup>4</sup>- T<sub>0</sub><sup>4</sup>.

The circles correspond to the measured values of heat and the triangles to the measured values of cooling.

Picture. Figure 2 shows the relationship between the output voltage U of a thermoelectric battery as a function of the difference between the fourth degree absolute temperature T of the furnace and the fourth degree absolute room temperature T<sub>0</sub>. This relationship is close to a straight line, as predicted by Stefan-Bolsman's law. [8] If the curve is studied carefully, we can observe a slight deviation from the well-matched straight line. This is due to the following effects: Measurements with a thermoelectric battery are affected by convection and radiation losses in the environment, especially when the glass hole is removed. [9] In addition, we cannot completely eliminate the increase in temperature at the thermoelectric battery comparison points as the furnace temperature increases.



### CONCLUSION

As a result of these measurements, we measured the output voltage of thermoelectric batteries by checking that the total emitted radiation of an absolutely black body by the Stefan-Bolsman law is proportional to the fourth degree of absolute temperature T. We measured the voltage U at a temperature of 450 ° C and in the interval until the absolute black body cooled to 0 ° C, and we obtained graph that voltage U (mV) depends on  $\frac{T^4 - T_0^4}{K^4}$ .

### REFERENCES

1. G.Ahmedova, I.Kholboyev, O.B.Mamatkulov “Atomic physics” Tashkent 2012
2. S.Bozorova, N.Kamolov “Physics” Tashkent 2007
3. E.V. Shpolsky "Atomic Physics" Teacher's Publishing House. Tashkent 1970
4. Sultanov N. Physics course. Textbook, T: Science and Technology, 2007
5. Detlaf A.A., Yavorskiy B.M., Kurs physics.Uchebnik -M.: “Academy”, 2007
6. A.I.Mamadjanov, A.R.Turg'unov, M.M.Umaraliyev “Investigate The Dependence Of The Light Refractive Index Of An Ideal Gas On Its Pressure Using Interferometers” International Journal Of Advanced 23: 1444
7. M.Umaraliyev, A.Turgunov “Measurement Of Heat Conductivity Coefficiency In Soil Samples” Scientific Bulletin of NamSU-2021 No. 5, page 34. ISSN: 2181-0427 ISSN: 2181-1458
8. AIMamadjanov, ARTurgunov “Kerr-NUT Black Hole Living Period” NamSU Scientific Bulletin-2019, No. 8, page 41.
9. A.I.Mamadjanov, A.R.Turg'unov “Measurement of Small Deformations with a Mach-Zehnder Interferometer” ISSN: 2632-9417 <https://doi.org/10.31295/ijpm.v4n1.1770>