

## FORMATIVE MOVEMENTS IN THE MACHINE WITH "NON-UNITARY" COORDINATION

Isamov Raim Nosimovich

Assistant

Bukhara Engineering-Technological Institute

Juraev Jurabek Malikovich

Assistant

Bukhara Engineering-Technological Institute

### ANNOTATION

The article covers methods and schemes for increasing the accuracy of shaping movements by replacing mechanical circuits with electronic circuits of coordinating movements, both between adjustable and stepper drives, and between two adjustable drives.

**Keywords:** electronic circuit, sensor, stepper drive, variable drive, averaging device, shaping movement, error, kinematic chain.

### INTRODUCTION

The accuracy of machines and mechanisms is the main characteristic of their quality. Mechanical transmissions (gear, rack, worm, etc.) are widely used in all branches of mechanical engineering, their accuracy is well studied, and they are constantly being improved in terms of both manufacturing technology and increasing accuracy. Kinematic chains based on mechanical transmissions are present in every machine tool, they are highly reliable, but they also have a significant drawback: gear wear.

In addition to the errors of the kinematic chains, the performance and accuracy of most machine tool mechanisms are largely influenced by the clearances in the joints, supports and transmissions. Clearances negatively affect performance, so designers are constantly looking for effective solutions to eliminate the clearances in completely or in part. In machines with hydraulic connections, hydraulics are used in the chains of the main movement, feed movements and auxiliary movements. With the help of hydraulics, the problem of continuous variable speed control is solved. However, hydraulic circuits have low reliability due to the increased complexity of circuit elements and their large number. In addition, the efficiency of such a scheme is low due to volumetric losses due to leakage of the working fluid, due to hydraulic losses due to a drop in pressure in the pipeline and a drop in pressure in the knees, due to intermediate energy conversions (electrical - mechanical - hydraulic - mechanical), which also contributes to an increase in losses [1].

It is possible to increase the accuracy of the coordination of shaping movements and pass the shortcomings of mechanical and hydraulic circuits only by switching to more precisely tunable electronic circuits that have a higher kinematic accuracy. They use electronic guitars, frequency-to-voltage converters, pulse transducers, etc.

## MAIN PART

### Coordination of Variable and Stepper Drives

Coordination of work between the drives of the main and auxiliary movements of the machine can be achieved using the diagram shown in Fig. 1. This is the simplest option; it is proposed to coordinate the operation of a variable drive (VD) and a stepper drive (SD), because stepper motors are often used in CNC machines. The stepper drive is used in continuous motion drives where the control action is given by a sequence of electrical impulses. Each incoming pulse activates the motor windings and causes discrete angular movements (steps) of the rotor. By changing the frequency of pulses arriving at the stepper drive, we achieve the required motor speed [2].

Here the movements of VD 1 and SD 5 must be coordinated. Pulse sensor (PS) 2 converts the movement of the output element of the variable drive into pulses. The averaging device (AD) 4 is a frequency divider. During the operation of the system, the speed of the VD is set by the direct current voltage signal  $U_3$ , which can be obtained from a typical "code-voltage" converter. Pulses from the pulse sensor with a certain frequency will go to a programmable frequency divider (PFD) 3, where the incoming pulse frequency will be divided by a given gear ratio encoded by signal K.

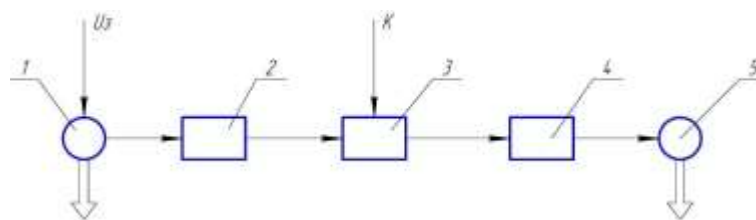

Fig. 1. Coordination of variable and stepper drives

1-VD; 2-impulse sensor; 3-PFD; 4-averaging device; 5-SD

After that, the pulses will go unevenly, which negatively affects the quality of processing, therefore, after PFD the pulses are fed to the averaging device, after passing through it, the resulting pulse frequency is fed to the stepper drive, setting the speed of the drive. After the introduction of  $U_3$  and K into the system, the VD and SD drives operate at preset speeds. A stepper drive allows high-precision conversion of electrical impulses directly into discrete angular displacements (steps) of the rotor, but it also has disadvantages. The disadvantages of stepper motors include instability of rotation during acceleration and deceleration, high cost and low power. In addition, the discreteness of the step creates significant fluctuations, which in some cases can lead to the excitation of mechanical resonances in the system.

In a variable speed drive, speed control is carried out by changing the voltage applied to the motor windings: the higher it is, the faster the armature rotates.

### Coordination of the operation of two variable drives

Because of the fact that the second motor is not a stepper motor, the circuit proposed in Fig. 1 takes on a more complex form and is converted into the circuit shown in Fig. 2. A pulse-to-constant voltage converter (PVC) is added to it, which is necessary to control a variable drive,

and a correction chain is introduced, which is necessary to compensate for the difference in engine speed from the required one, due to the floating characteristics of the variable drive.

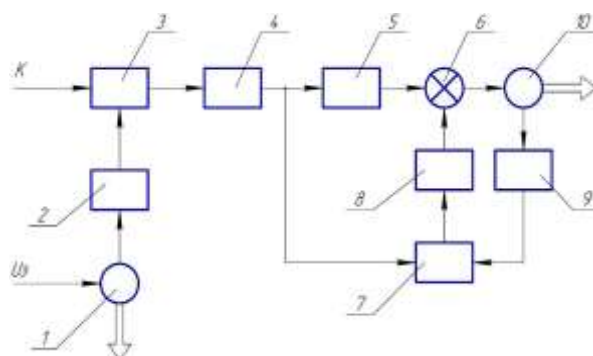

Fig. 2 Coordination of the operation of two variable drives

1, 10- VD; 2, 9- pulse sensor, 3- PFD; 4- averaging device; 5- PVC; 6- adder; 7-trigger discriminator;

Here, the movements of the variable drives must be coordinated, PS<sub>1</sub> 2 and PS<sub>2</sub> 9 convert the movement of the output elements of the drives into pulses, the PFD 5 converts the pulse frequency into a constant voltage, and the trigger-discriminator 7 compares the two sequences of pulses in frequency and phase, the filter 8 smooth the incoming pulses. When operating the system, the speed of the RP1 1 drive is programmed with a direct current voltage signal  $U_3$ , which can be obtained from a typical "code-voltage" converter. The speed of movement of the VD<sub>2</sub> 10 drive is programmed with a coded signal K, which sets the division factor of the PFD 3. After the PFD, the pulses will go unevenly, which negatively affects the processing quality, therefore, after the PFD, the pulses are fed to the averaging device 4, after passing through it, the received pulse frequency is fed to the input of the frequency converter pulses into a voltage, which, depending on the input frequency, produces a certain voltage level. The resulting voltage is fed through the voltage adder 6 to VD<sub>2</sub>. After the introduction of  $U_3$  and K into the system, the drives VD<sub>1</sub> and VD<sub>2</sub> operate at preset speeds. In this case, the frequencies and phases of the pulses coming from the PFD, passing through the averaging device, and from PS<sub>2</sub>, are compared by the trigger-discriminator (TD) and the comparison result is issued in the form of a pulsating voltage. If there is a mismatch, then the voltage from the trigger is supplied, passing through the filter (to smooth out voltage surges), to the adder, where it either increases the voltage setting the speed of the VD<sub>2</sub> drive, or decreases it. This will happen until the given rotation speed, determined by the frequency of pulses from the programmable frequency divider, and corresponds to the available rotation speed, which determines the frequency of pulses from the PS<sub>2</sub> sensor.

#### Description of ways to improve the scheme of coordination of movements for two variable speed drives

There are ways to improve the coordination of movements scheme for two variable speed drives. This is achieved by paralleling the signal with PS<sub>1</sub> with the possibility of correcting it. New

elements appear in the circuit, created to improve the accuracy of signal transmission from  $VD_1$  to  $VD_2$ .

Depending on which pulse transducer is used to convert the displacement of the variable drive output element into pulses, the methods for creating parallel signals will differ. A large number of measurement steps per revolution characterizes high-resolution sensors. At lower processing speeds, you can use sensors with low resolution and fewer measurement steps per revolution. The difference is that with low resolution, it is possible to set two reading elements in the step size, but with high resolution, it is not. In the case of low resolution, two independent signals are obtained, always different in time, and with high resolution, one signal is obtained, which will be triggered on two parallel circuits.

Let us refer to the developed circuit proposed in Fig. 3, which shows an improved circuit with two variable speed drives (1 and 15). This case is considered for a pulse generator PS1 2 with low resolution, that is, the signal is taken from two sensor-reading elements and each is sent to its own PFD (3 and 12). Here, the possibility of correcting the operation of  $VD_2$  15 is provided by correcting the main signal of the  $PVC_1$  3 using the  $PVC_2$  signal 12, the direction of decreasing or increasing the frequency is set by the input "+/-". Depending on how the circuit of the element 4 and keys 5 and 13 will work, the pulse-phase converter (PPC) 6 will add pulses from the  $PVC_2$  to the sequence from the  $PVC_1$ , or subtract them.

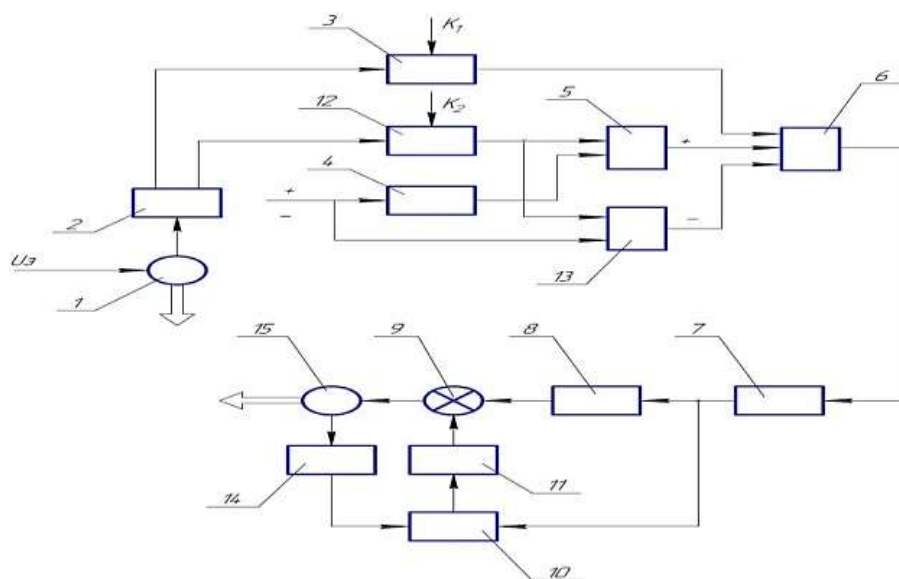

Fig. 3. Coordination of operation of two variable speed drives with signal correction for a sensor with low resolution

1, 15- VD; 2, 14- pulse sensor; 3,12- PFD; 4- NO element; 5, 13- key; 6-PPC; 7-averaging device; 8-PVC; 9- adder; 10- trigger discriminator; 11- filter

Thereby, in the circuit with a low-resolution sensor, the issue of accurate signal transmission is solved and the possibility of its correction is given.

In the case of  $PS_1$  2 with high resolution, the signal comes from one reading element and is supplied to the  $PFD_1$  3 and  $PFD_2$  16. After passing the PFD, the pulse sequences will have different frequencies, since  $K_1$  and  $K_2$  are different from each other, but the pulses can be

superimposed, or duplicate each other. Therefore, PPC 6 may not work correctly without adding pulses with PFD<sub>2</sub>. It is proposed to solve this problem by introducing a synchronization unit 12 into the circuit, which serves to shift in time the arriving pulses relative to each other (Fig. 4) [3].

The rest of the circuit repeats the operation of the circuit with a low-resolution sensor (Fig.3). In the two considered schemes Fig. 3 and 4, it was proposed to correct the signal both in the positive direction and in the negative direction using the signal from the "+/-" input. There are machines that require signal correction only in one direction, therefore, consider the simplified schemes proposed in Fig. 2.5-2.8, with signal correction only in positive or only in negative directions, relying on a circuit with a low-resolution sensor, Fig. 3.

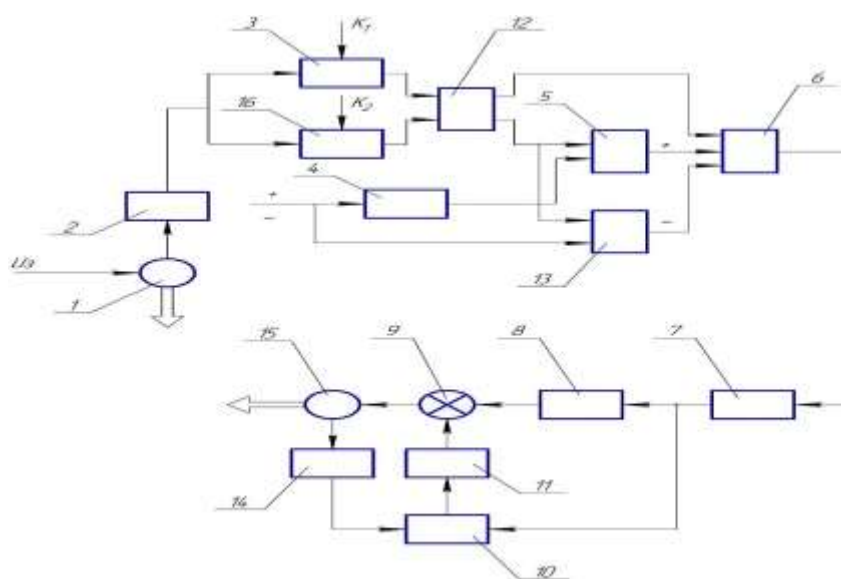

Fig. 4. Coordination of operation of two variable speed drives with signal correction for a sensor with high-resolution

1, 15- VD; 2, 14- pulse sensor; 3,16- PFD; 4- NO element; 5, 13- key; 6-PPC; 7-averaging device; 8-PVC; 9- adder; 10- trigger discriminator; 11- filter

First, let us turn to the scheme with negative correction (Fig.5). In this case, the signal is supplied from two reading elements PS<sub>1</sub> 2, and each is fed to its own PFD, with its own coded signal K. Then, the signal from PFD<sub>1</sub> 3 is supplied to key 4, and the signal from PFD<sub>2</sub> 13 to RS-trigger 10, periodically closing it, so that the next PFD<sub>1</sub> impulse cannot pass. The PFD<sub>1</sub> sequence has a higher frequency than PFD<sub>2</sub>. Thus, the number of pulses arriving at the PVC 6 decreases, therefore the driving voltage of the RP<sub>2</sub> drive decreases. After the key, averaging device 5 is installed to align the sequence of pulses. Adding synchronization block 11 to this scheme, we get a case for a sensor with high resolution (Fig. 6).

Now let us turn to the scheme with a positive correction (Fig. 7). In this case, the signal is also supplied from two readout elements PS<sub>1</sub> 2, and each is fed to its own PFD, with its own coded signal K. Then the signal goes to the OR element 4. Here, it is impossible to simultaneously arrive at the OR input, since the signals were removed from the PS<sub>1</sub> sensor at different times. Therefore, the signals from the PVC<sub>2</sub> 10 will always be added to the sequence from the PVC<sub>1</sub> 3.

This increases the number of pulses arriving at the SD 6, therefore the setting voltage of the VD<sub>2</sub> drive increases. For uniformity of impulses after OR, there is averaging device 5 is installed.

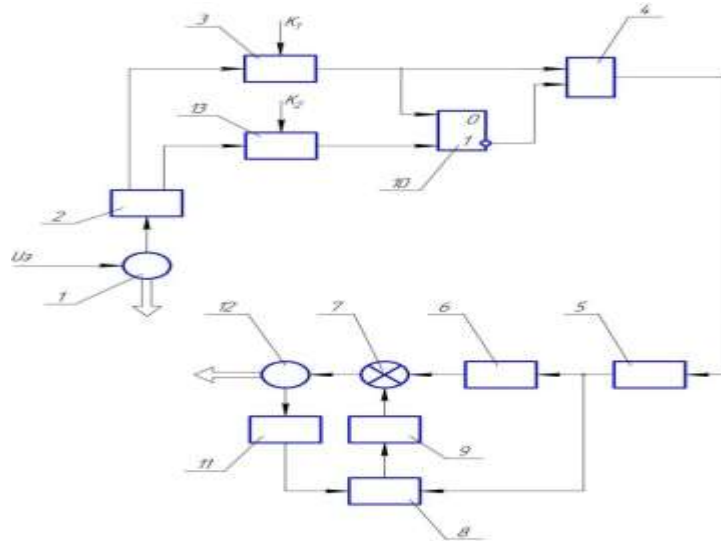

Fig. 5 Coordination of operation of two variable speed drives with negative signal correction for a sensor with low discreteness

1, 12- VD; 2, 11- pulse sensor; 3, 13- PFD; 4-key; 5- averaging device; 6- PVC; 7- adder; 8- trigger discriminator; 9- filter; 10- RS trigger

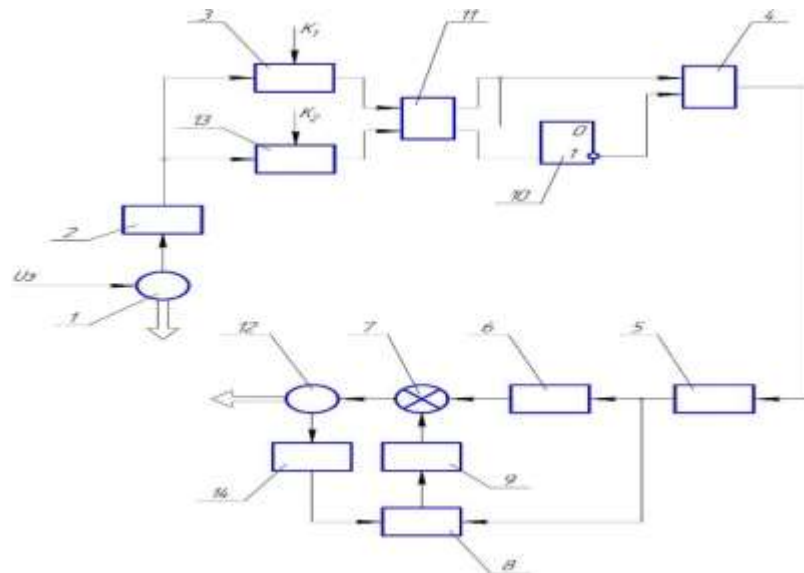

Fig.6 Coordination of operation of two variable speed drives with negative signal correction for a sensor with high resolution

1,12- VD; 2,14- PS; 3, 13- PFD; 4-key; 5-averaging device; 6-PVC; 7-adder; 8-TD; 9-filter; 10- RS trigger; 11-BS

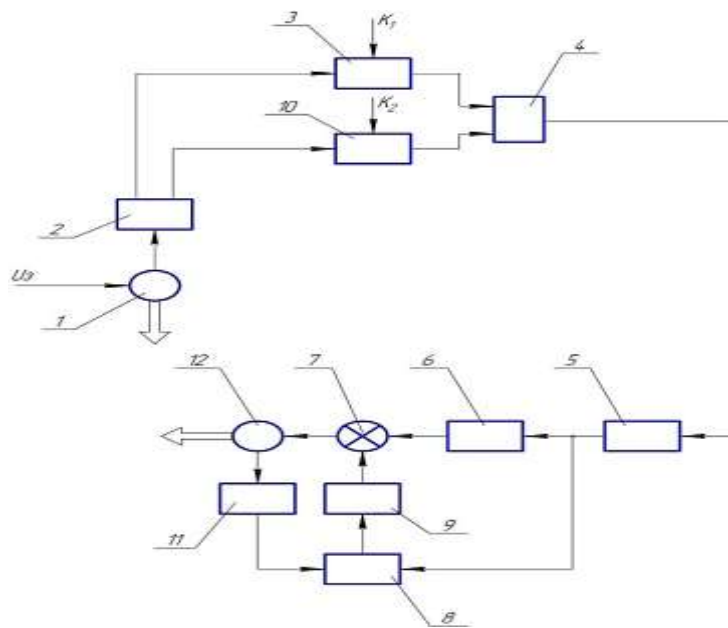

Fig. 7 Coordination of operation of two variable speed drives with positive signal correction for a sensor with low resolution  
 1, 12- VD; 2, 11- pulse sensor; 3, 10- PFD; 4-element OR; 5- averaging device; 6- PVC; 7-adder; 8-trigger discriminator; 9- filter

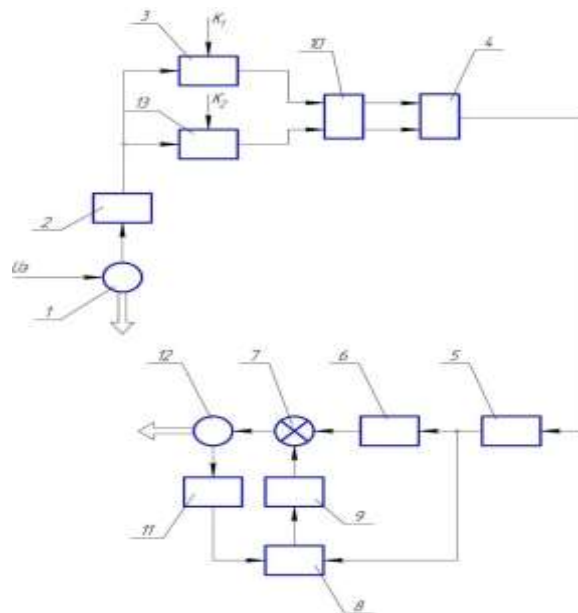

Fig. 8 Coordination of operation of two variable speed drives with positive signal correction for a sensor with high resolution  
 1, 12- VD; 2, 11- pulse sensor; 3, 13- PFD; 4-element OR; 5- averaging device; 6-PVC; 7- adder; 8- trigger discriminator; 9- filter; 10- BS

Adding synchronization block 10 to this diagram in Fig. 7, we receive the case for sensor with high resolution (Fig. 8).

## CONCLUSION

The methods and schemes for increasing the accuracy of shaping movements were considered by replacing mechanical circuits with electronic circuits for coordinating movements, both between variable and stepper drives, and between two variable drives. In circuits using a stepper drive, it is recommended to use a programmable frequency divider on a binary counter and a circular shift register together. For circuits with only variable drives, by paralleling the signal from the pulse generator, the signal transmission accuracy from the sensors with low and high resolution is increased, which is very important for high-speed processing. In the proposed schemes, it is possible to correct the signal deviation, both in directions of its increase and decrease, and both together and separately. The use of electronic circuits for coordinating the shaping movements of machine instead of mechanical chains almost completely eliminates the kinematic error, thereby increasing the accuracy and efficiency of processing.

## LITERATURE

1. Bushuev V.V., Eremin A.V., Kakoylo A.A. and others. Metal-cutting machines: textbook. In two volumes / edited by V.V. Bushuev. Vol.2. - Moscow: Mechanical Engineering, 2011, p. 594; illustrated
2. Liberman J.L. Development of technical specifications for design of metal-cutting machine CNC systems: Methodical instructions for course work of the course "Control systems for machine tools and machine complexes." Yekaterinburg: USTU-UPI. 2009, p. 51
3. Patent of Russian Federation No. 160852. Lieberman Ya.L., Kuchin S.G., Chepusova E.Yu. Device for coordinating the shaping movements of work member of machine tools.