

PHOTOMAGNETIC CONVERTER

Onarkulov Karimberdi Egamberdievich

Professor, Fergana State University

Yuldashev Shohjahon Abrovich

Doctoral Student, Fergana State University

Yuldashev Abror Abduvositovich

Teacher, Fergana State University,

Yuldasheva Shahrizoda Abrorjon qizi

Student, Fergana State University

ANNOTATION

An optoelectronic miniature device for obtaining large electric fields from solar radiation using the magnetic field of various natural and artificial sources has been developed and studied. The design of the technology for manufacturing epitaxial thin films is proposed. The device does not require a separate external power supply to operate. This optoelectronic converter ensures the autonomy and independence of the system. Such photo magnetic converters are used as photovoltaic stimulators of various chemical and technological processes and means of sorting complex molecular flows.

Keywords: Optoelectronic converter, FME-effect, photoelectric stimulator, optosystem, AFN element, Led, epoxy resin, matrix, thin film technology.

INTRODUCTION

The device belongs to the field of optoelectronic technology, or rather, photovoltaic devices designed to generate electric fields using a magnetic field. The invention makes it possible to convert the magnetic fields of various sources (e.g., the magnetic field of the earth, the magnetic field of biocurrents, the magnetic field of high-voltage lines, etc.) into an electric field optoelectronically. . There are different ways to obtain electric fields of a certain intensity, but in these devices the source is a conventional power source with a sufficiently high power. The main element of such devices is a high-power external power source, the cost of which is a significant share of the cost of the entire device of the converter in electromagnetic methods of generating strong electric fields, along with large power consumption. from external power sources. Thus, in terms of microminiaturization and energy saving (energy saving), the possibilities of traditional methods of obtaining large electric fields using an electromagnetic source of electricity are almost complete. A radically different perspective approach to obtaining strong electric fields based on the use of photovoltaic effects in non-homogeneous semiconductor structures is carried out in the devices closest to the claimed device in technical essence [1]. The basic element for all optoelectronic devices is an optocoupler consisting of a light source and a photodetector. In the devices proposed in [1], the light source is a low-divergence ray of solar radiation. In these studies [1], an electric field is obtained using a stream of light.

The proposed optoelectronic converter, unlike other similar optoelectronic devices [1], uses magnetic fields from various external sources in areas of solar radiation. Large electric fields are widely used in various fields of science and technology. The use of this device in quantum group devices opens up the possibility of microminiaturization, energy saving and increasing the reliability of the device. In addition, large electric fields are used in electroadhesive grip systems and robotic fastening systems to increase system reliability, autonomy, and energy independence.

Large non-homogeneous electric fields are used in chemical and technological processes as a photoelectric stimulator of processes and a sorting medium for complex molecular currents [2]. With the use of the proposed device in a microelectronic optosystem, the contactless remote control of optoelectronic devices is improved, and the sensitivity and reliability are increased by several degrees in Figure 1 [1]. a schematic block diagram of an optoelectronic magnetic-optical converter is given

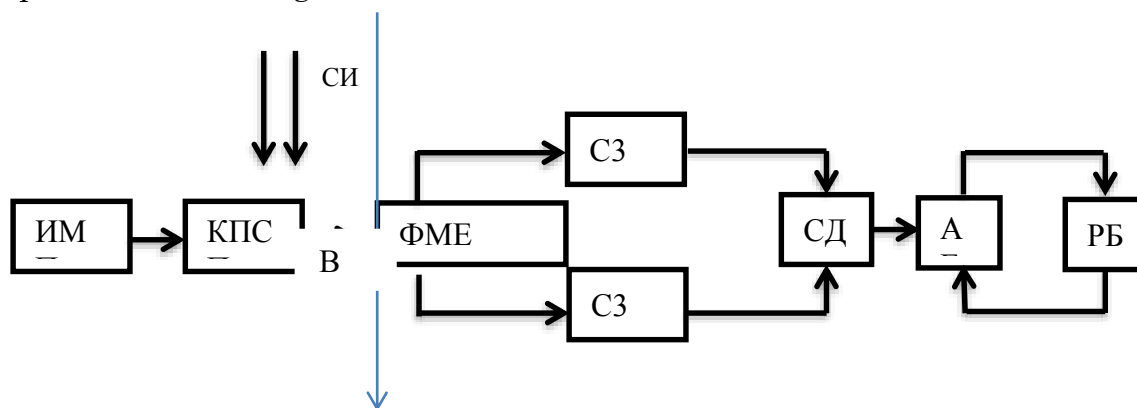

Figure 1 Photomagnetic converter from magnetic field to electric field.

ИМП – magnetic field source.

СИ - solar radiation flux.

КПС – solar flux (radiation) intensity control block

ФМЕ – When a photomagnetic element is placed in a magnetic field perpendicular to the ФМЕ light beam, a non-homogeneous semiconductor in which photomagnetic Э.Д.С. is generated. (ФМЕ effect, photomagnetolectric effect)

СЗ – high input impedance link, which consists of a cathode tracker in МОП

СД – LEDs (operating current approximately 100mA, operating voltage 1–30V) - These are devices that emit light when current is passed. The main advantage is low power consumption without loss of brightness and light output. LEDs do not have an ultraviolet component in their light spectrum.

АЭ – АФН – element eto fotopriyomnik rabotayushchiy v regimee elektricheskogo generatora s opticheskim pitaniem t.e. АЭ poluchaya svetovoy stream, preobrazuet v elektricheskoe pole.

РБ – external operating block or output device (load)

В – external operating block or output device (load)

Ustroystvo rabotaet sleduyushchem poryadke

If a photomagnetic element ($\Phi M \Theta$) is in a magnetic field, low-divergence light rays (possibly sunlight rays) perpendicular to the direction of the magnetic field will pass; Abnormally high photomagnetic voltages ($A \Phi M$) occur in $\Phi M \Theta$. [3].

Using an electrical circuit through $C3$, which enters the LED light-emitting diode, an abnormally high photomagnetic voltage is again converted into an electromagnetic wave (light). The LED light signal is transmitted to the $A \Phi H$ -element ($A \Theta$) via an optical channel. $A \Phi H$ -element ($A \Theta$) is an electric generator with optical power that generates abnormally large photovoltaics ($A \Phi H$).

$A \Phi H$ – element is a non-homogeneous polycrystalline structure consisting of several micro-photo hetero-compounds or other barriers connected in series. When such a non-homogeneous semiconductor is illuminated, a very important common gate photograph appears in it. $\Theta. \Delta. C$ [4]. $BA \Theta$ the energy of the magnetic field is converted into an electric field with great intensity. The optocoupler $C \Delta - A \Theta$ used a low-power (approximately 6W small) LED matrix as the light source, generating light like a 60-watt incandescent lamp, and consuming 8 times less power. Another advantage of the LED lamp is that it does not generate heat during operation. It is known that when $A \Theta$ is heated, the process of APN formation is greatly disrupted [6]. There is also an LED in the spectral composition. ($C \Delta$) has no ultraviolet component [7]. By providing the proposed device with a protective coating from a plastic cast epoxy compound (type E-6 epoxy resin), we provide reliable protection of it from external influences (temperature and vibration) in real working conditions.

High stability, the sensitivity of the device is provided by the PME-sensor [8], which has a wide range of magnetic field sensitivity, which is of great interest for creating sensitive magnetic field sensors because of the typical stationary PME effect. The $A \Phi H$ structure [8] already exceeds the sensitivity to the magnetic field of the Hall sensor in order of magnitude. The maximum non-stationary $\Phi M H$ can exceed the stationary value several times. In a 19 $\kappa \Theta$ order magnetic field, the photomagnetic voltage (PMV) reaches 70V.

To use this device in industry, you can use epitaxial thin film production technology. The design of the thin-film execution of the devices is presented Fig.2.

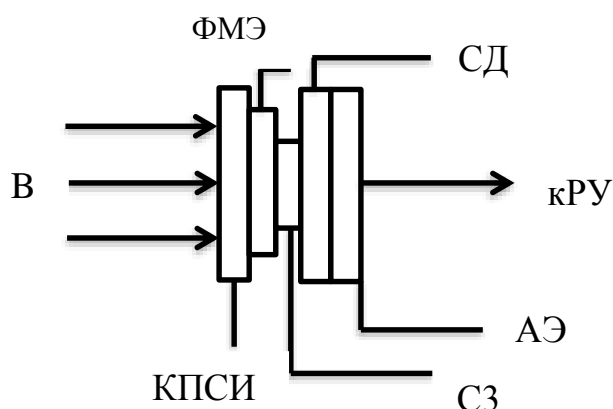

B – magnetic field induction

$КПСИ$ – control of light flux (solar radiation);

ФМЭ – fotomagneto-elektr magnit maydon sensori
СЗ – thin film МОП structure for the corresponding link
АЭ – АФН element to generate high voltage
РУ – working device

Basic specifications

1. LED current 0.03-0.04A, voltage 1-30V, light current 240-300 lumens
2. Order weight: 150g
3. Spectral range: visible and near infrared.
4. Operating temperature: room temperature, 20-25 0C
5. Housing: supporting structure, made of (dielectric) plastic with cast epoxy resin, instead of attached to the bracket, type e-6.
6. The intensity of the electric field at the output of the device (maximum) is 105 V / cm

CONCLUSION

A high-sensitivity ФМЭ element is used in an optoelectronic converter to obtain strong electric fields, when the ФМЭ element is placed perpendicular to the magnetic field, light rays are absorbed by a non-homogeneous semiconductor made of thin-film cadmium telluride with isovalent compounds, photomagnetic electromagnetism appears, the corresponding link and the LED form an electrically closed loop. The pair of optocouplers consists of an LED and an AE element made of SMS structures with p - n transitions. The receivers of the optical radiation of this optocoupler are non-homogeneous anisotropic АФН - a structure with cubic lattice symmetry broken in the preferred direction from the individual directions of the pairs of isovalent compounds. This anisotropy is the result of oblique (curved) subsidence of the material (CdTe). As a result of such unevenness of the surface regions of the АФН-structure, anisotropic inhomogeneous light is generated, leading to the appearance of large anomalous high photovoltages. This voltage creates a high-intensity electrostatic field at the output.

REFERENCES

1. Онаркулов, К. Э., Юлдашев, Ш. А., & Юлдашев, А. А. (2022).
2. ОПТОЭЛЕКТРОН ТУНДА КЎРИШ МОСЛАМАСИ. NamDU ilmiy
3. axborotnomasi, 56-61.
4. Юлдашев, Ш. А., Юлдашев, А. А., & Юлдашева, Ш. А. (2021). ОПТОЭЛЕКТРОННЫЕ ПРЕОБРАЗОВАТЕЛИ. Илмий-амалий конференция, 151-153.
5. Патент Германии, ЭС – 01 – 002678 от 10.02.2020г.
6. Патент Германии, ЭС – 01 – 001725 от 18.05.2020г.
7. Патент Германии, ЭС – 01 – 002677 от 10.02.2020г.
8. Нуридинова Р.Л., авт.реф.дисс. доктора философии Phd по техн. Наукам. Ташкент 2019.
9. В.Н.Агарев, В.И.Стафеев ФТТ, Вестник Нижегородского университета им. Н.И.Лобачевского, 2013, №2 (1), с.36-38
10. Авторское свидетельство СССР, 1967, 4с, 2-сп, №210279.
11. Патент Германии №ЭС-01-002505, й9.10.2019

12. Фотоэлектрические явления в полупроводниках и оптоэлектроника, Изд. “ФАН”
Ташкент, 1972 с.161
13. В.Л.Козлов Оптоэлектронные датчики, Минск, БГУ, 2005
14. ФТП, том5, в.7,1971,стб 1415.