

## A TRAP THAT TRAPS HEAVY IMPURITIES IN COTTON

Rayimjonov Mirzavali Botirali o'g'li

PhD doctorant of Namangan Institute of Engineering and Technology

*Tel.:(998) 94 270-0616, e-mail: (mrayimjonov6@gmail.com)*

Pirnazarov Abdurasul Umataliyevich

Doctor of Technical Sciences and DSc of Namangan Institute of Engineering and Technology

*Tel.:(998) 93 912-3500, e-mail: abdurusul1981@gmail.com*

Muradov Rustam Muradovich

Professor and Doctor of Technical Sciences of Namangan Institute of Engineering and Technology

### ANNOTATION

The iron sheets in the pocket of the device that catches heavy objects open automatically when the load is lowered with the help of an electromagnetic spring and sensors. The seeded cotton goes directly to the working return surface, which prevents damage to the seeded cotton and separates the accumulated part of the cotton.

**Keywords:** stoneware; plate; pneumatic transport; sensor; a lover; trapezium; oblique shape; pocket

### INTRODUCTION

In cotton ginning enterprises, cotton is transported from the gins to the drying, cleaning and ginning shops of the production enterprises in pipelines with the help of air. During the transportation of cotton in pipelines, stone catcher devices are used to separate the heavy impurities in its content. These devices are usually installed in the transition part of the cotton from the horizontal direction to the vertical direction. In the working chamber of this device, cotton changes its direction from horizontal to vertical, and its speed also decreases. Reducing the speed makes it possible to separate heavy compounds from cotton. In the working chamber, the cotton is separated from the heavy impurities when it rises up in the air stream in the vertical direction. According to the conducted studies, the efficiency of stone catchers installed in the technological process of cotton ginning enterprises is around 70%. The main reason for the low efficiency of stone traps is that the cotton gets into the working chamber in bunches without shaking. Heavy objects include stones, lumps, pieces of iron, and similar objects. As a result, raw cotton is sent from the cotton gin to the pipelines by the workers for cleaning, ginning, ginning, linting, and pressing processes. Cotton is pulled at high speed by pneumatic transporters. Due to the fast work of the workers, the heavy impurities around and inside the bundle are added to the cotton raw material and transferred to other processes. Heavy mixtures can cause fires due to drying and friction on other equipment. cotton is a flammable product. and the failure of the cleaning equipment parts to break will cause the motors to burn out, the

warping of the saws to break, which will lead to very bad consequences and high costs. In order to solve these problems, a number of research works were analyzed.

### MAIN PART

It is proposed to install cone-shaped guides in the inlet pipe of the stone catcher device created by T. Makhamedov (Fig. 1). These guides are placed in a checkerboard shape and serve to cut cotton coming into the working chamber. In addition, in the working chamber of the stone catcher of cotton, the working chamber prepared as a step on the surface in front of the inlet pipe, helped to tighten the cotton [1].

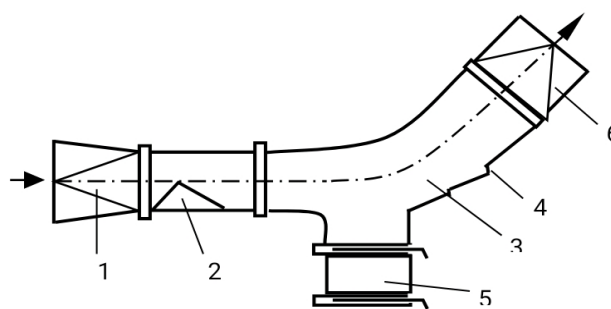

**Figure 1. Freezer**

1-inlet pipe, 2-cone-shaped divider, 3-separation chamber, 4-stair-shaped returner, 5-pocket,  
6-outlet pipe.

Several new constructions have been invented by the researchers who conducted scientific research in this direction in order to increase the efficiency of stone traps. It was proposed to install a pair of drums with blades for crushing cotton in the inlet pipe of the working chamber (Fig. 2).

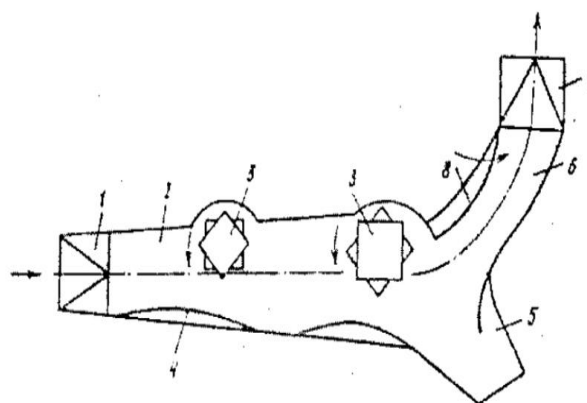

**Figure 2. Cotton cleaner from heavy impurities. SU 1516518.**

1-inlet pipe, 2- chamber, 3-accelerating drums, 4-rib guide, 5-dirt separation chamber, 6-pass,  
7-exit pipe, 8-guide upper rib.

This stone holder works as cotton[2]. The seeded cotton coming with the help of pneumatic transport enters the working chamber 2 of the device through the inlet pipe 1, and the seeded cotton is transferred to the accelerator 3 in the ribbed guide 4, and the seeded cotton is weighed using the ribbed guide 8 installed in the upper part of the chamber. It helps the mixture to fall into the lower chamber 5. The seeded cotton, cleaned of heavy impurities, goes out of the outlet pipe 7 through the corridor 6.

Similar to this device, we would like to propose a new construction. The new stone crusher is different from the others in terms of its construction, and its working surfaces and its new type of mechanisms are used in the structure.

The structure of the device is that the seeded cotton enters the working chamber through the inlet pipe, the seeded cotton goes directly to the working return surface, it prevents damage to the seeded cotton, and the accumulated part of the cotton is separated. Heavy impurities in cotton fall into the lower pocket through a device made of a certain rubber, the structure of the pocket has a trapezoidal structure. In order to ensure that air does not enter from the outside during the capture of heavy mixtures, the first iron plate that lowers heavy objects is placed perpendicular to the pocket, and the second is installed at the bottom of the trapezoidal pocket in the form of a vertical slant. To ensure that these plates can be opened and closed by themselves, the first part of the plate, fixed to the surface of the pocket, is fixed with a spring. This ensures that when a heavy load falls on the plate, it will drop the load by itself. The second plate is installed in the same way as the first one, but in order to ensure air tightness, an electromagnet and a sensor are used together with a spring. When the load is lowered and the first plate is closed, the sensor gives a signal and the current is cut off and the plate opens, then the heavy mixtures fall, the current comes quickly and the spring pushes the plate and closes it, sticking to the electromagnet.

## CONCLUSION

In short, this construction that we offer prevents the effect of trapping heavy impurities in cotton and the damage of cotton. The goal of automatic opening and closing of pockets is to reduce the human factor, which protects human health and prevents the worker from being distracted from other work. Germination of the seed leads to the need to ensure that the hopper does not get mixed with the cotton raw material. A major factor in the breakage of saws during the ginning process is the addition of a heavy mixture to the cotton raw material. In this process, the fiber quality is degraded and may break. The device offered by us leads to the smooth flow of these processes and the smooth flow of currents in the entire enterprise, the smooth operation of equipment, the prevention of burning of divigatels, the prevention of fires in dryers and other devices, and the prevention of damage to devices. Increasing the efficiency of the refrigerator is the large number of pockets and the automatic opening of the pockets. Then, the excess of working surface causes the separation of the accumulated raw cotton, and then a spring plate is placed on the impact site to prevent damage to the cotton. It prevents the accumulation of heavy compounds on the plate during the trapping process and saves the risk of damage to the machines in the next process. This device is fundamentally different from others in its construction structure. It also prevents fiber vachitis damage in cotton ginning plants.

### REFERENCES

1. R. M. Muradov, S. Husanov, A. Karimov - "Ways to improve the efficiency of devices that trap heavy impurities in cotton" Namangan-2017.
2. R.M. Muradov, O. Mamatkulov. Scientific newsletter of Namangan State University "Improving the design of multi-pocket stone crusher" - 2011.
3. G'.J. Jabbarov, T.U. Atametov, A. Khamidov. "Technology of initial processing of seed cotton" - Tashkent. "Teacher"-1987